

# Electrical Window Opener - Chain Drive 300N-300mm

HCM 24-36-48VDC / HCMA 230VAC / HCMARemote 230VAC

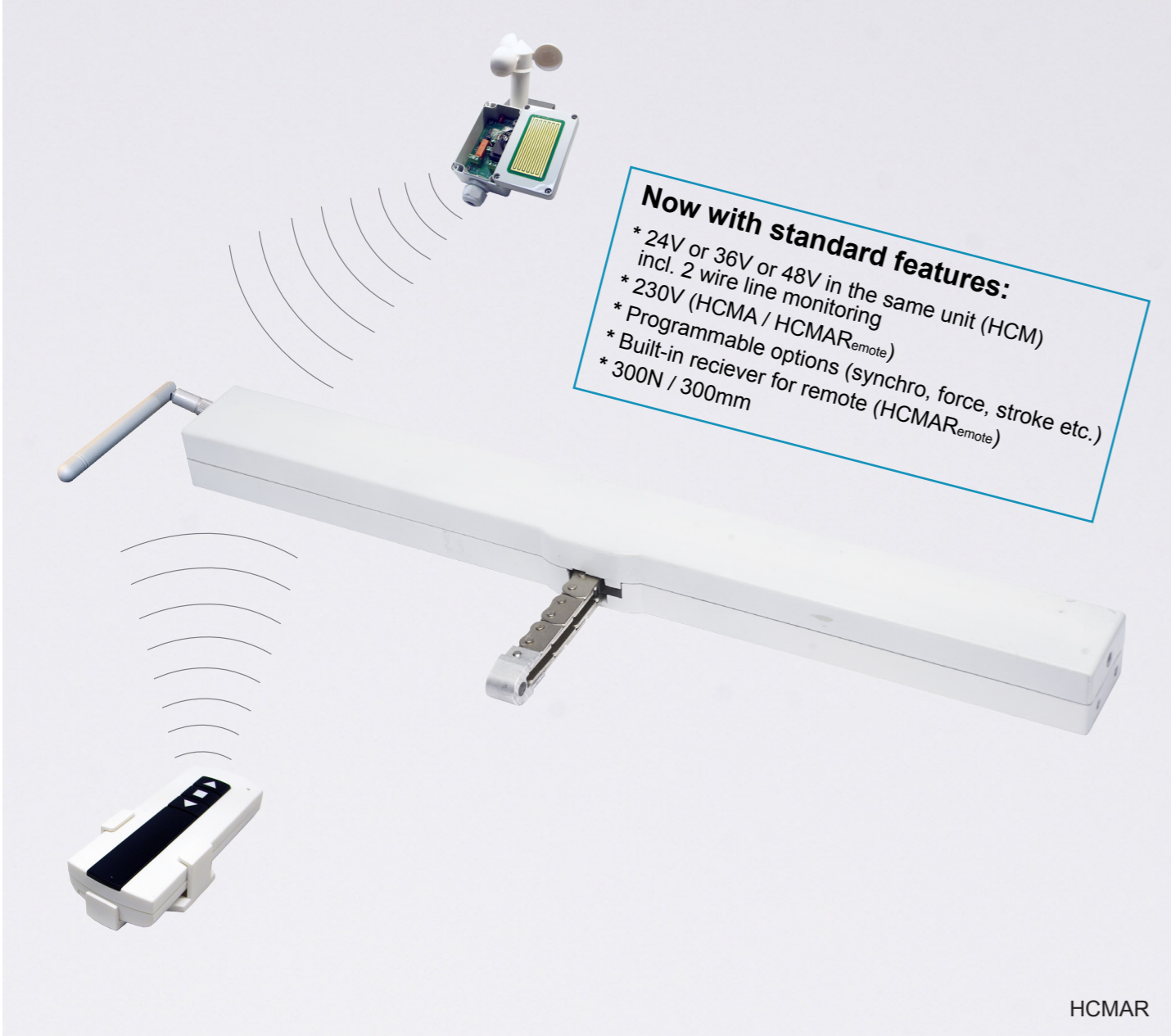

HCMAR

- For roof windows, façades and skylights
- Compact and elegant design
- Power supply:
  - 24-36-48VDC (HCM)
  - 230VAC (HCMA / HCMAR<sub>remote</sub>)
- Programmable options:
  - Synchro mode (up to 4 drives)
  - Force (push, pull, soft close)
  - Speed
  - Stroke length
  - Soft close length
- 2 wire line monitoring (HCM)
- Soft close function

- Stroke length: 300mm as standard (can be reduced by programming)
- Pushing/pulling force: 300N as standard (can be reduced by programming)
- Built-in electronic overload protection
- Low noise level
- Tested to min. 11.000 cycles
- 2.5m silicon cable
- Housing in white coated aluminium
- Symmetrical chain exit (in proportion to the housing)
- Integrated receiver + remote control (HCMAR)
- Receiver is compatible with Wind & Rain Sensor #111960 and #111961



HCM / HCMA



HCMAR<sub>remote</sub>

Model	Power supply	Pushing / pulling force (N)	Stroke length (mm)	Locking pressure	Protection	Temperature	Speed	Size (LxWxH mm)
HCM 300N/300mm	24VDC / 0.8A 36VDC / 0.6A 48VDC / 0.4A	300 / 300	300	2000 N	IP 32	-5° C - +55° C	6.8 mm / sec.	451 x 48 x 34
HCMA 300N/300mm	230VAC / 15W	300 / 300	300	2000 N	IP 32	-5° C - +55° C	6.8 mm/sec.	451 x 48 x 34
HCMAR 300N/300mm (integrated receiver + remote control)	230VAC / 15W	300 / 300	300	2000 N	IP 32	-5° C - +55° C	6.8 mm/sec.	451 x 48 x 34

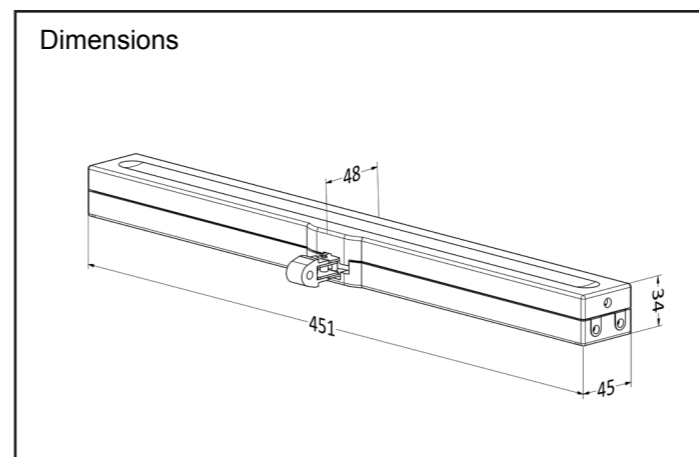

Dimensions

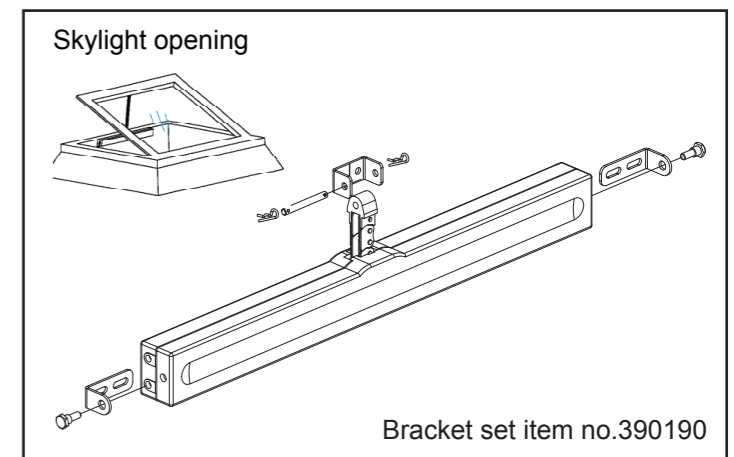

Skylight opening

Bracket set item no.390190

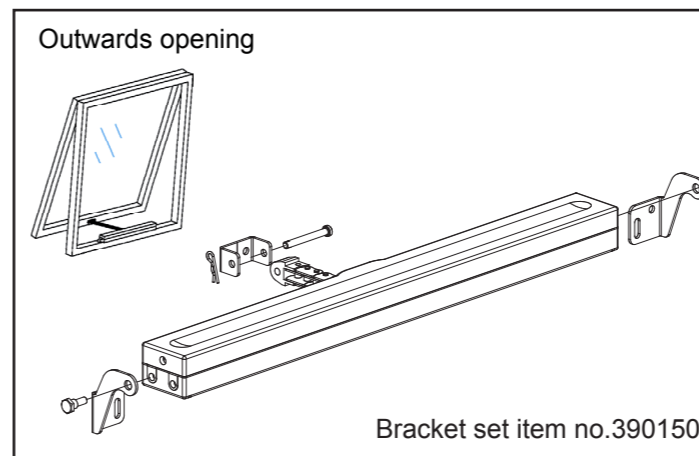

Outwards opening

Bracket set item no.390150

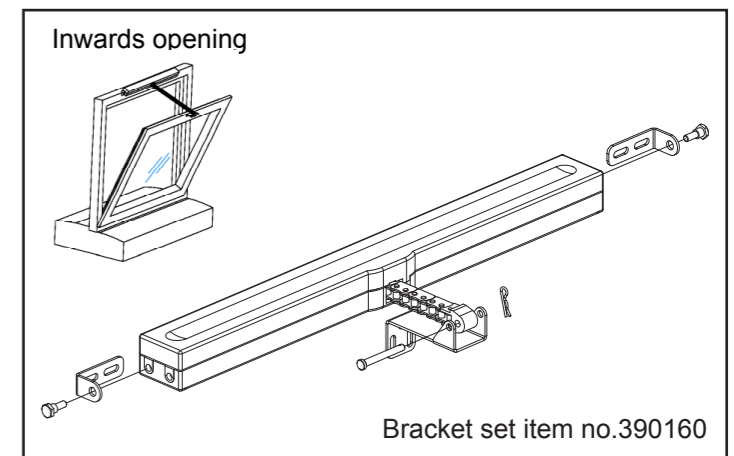

Inwards opening

Bracket set item no.390160